

RIGEL®

INSTRUCTION MANUAL

LU1119/

LU1119-1

Undercounter Lavatory

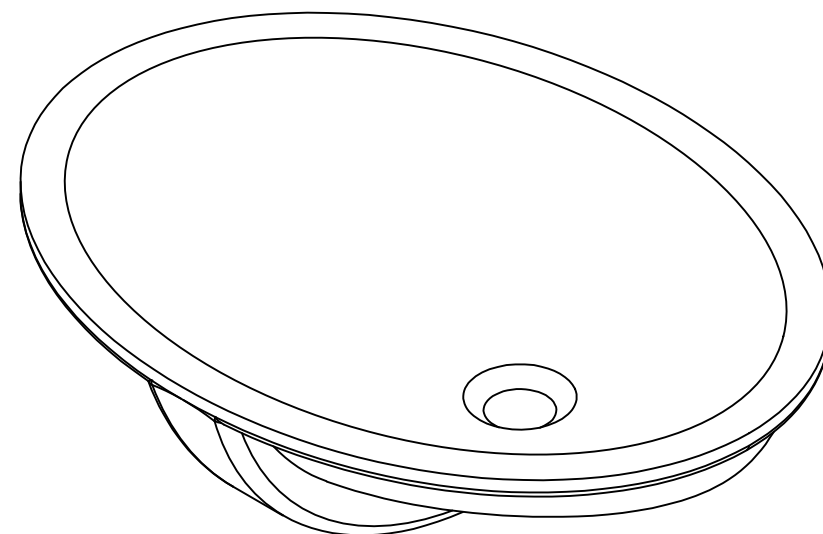

IMPORTANT SAFETY INFORMATION

The instructions contained herein are for the safe and correct use, care and maintenance of the product, to minimize the risk of injury and damage to yourself, other persons, or property.

Please read the following safety information thoroughly and retain this document for future use and reference.



WARNING

Instructions accompanied by this symbol could lead to death or serious injury if they are ignored or followed improperly.

IMPORTANT SAFETY, INSTALLATION AND OPERATING INSTRUCTIONS

Please read this manual and ensure that you understand the instructions and procedures stated within before installing or operating the product.

Rigel products have been designed and tested to be safe and risk-free when installed, operated and maintained in good working order, in accordance with the instructions and recommendations found in this document.

There are no user-serviceable parts in this product. Please contact a qualified and licensed trades person should the product require dismantling and/or repairs.

Supervision should be given to any persons who may have difficulty understanding or operating the controls of the product. Extra consideration should be given to the young, infirm, elderly, or any person inexperienced in the correct operation of the product's controls.

DISCLAIMER

While every effort has been made to ensure that the information contained within this document was accurate and complete at the time of printing, Rigel Technology (S) Pte Ltd shall not be held responsible for any errors, omissions or inaccuracies. By installing or using the product, the user agrees that no responsibility for the consequences resulting from any misinformation shall be incurred on Rigel Technology (S) Pte Ltd. Rigel Technology (S) Pte Ltd reserves the right to change the specifications and functions of the product described herein at any time without prior notice.

No part of this guide may be reproduced, stored in a retrieval system, or transmitted, in any form or by any means, electronic, mechanical, recording, or otherwise, without the prior written permission of Rigel Technology (S) Pte Ltd.

CUSTOMER SUPPORT

VIETNAM

RIGEL TECHNOLOGY (INDOCHINA) LLC | Office & Showroom

Address : No. 207-209 Phan Dang Luu Road, Ward 1, Phu Nhuan District, Ho Chi Minh City, Vietnam

Tel Number : (84) 28 3600 3700

Fax : (84) 28 6255 3939

E-mail : sales.vn@rigel-group.com

Website : www.rigel.com.vn

CHINA

RIGEL SANITARY SHANGHAI CO., LTD 锐佳洁具（上海）有限公司 | Sales & Marketing Office

Address : 7th floor, Building 1 of Hongqiao Hub, 818 Shenchang Road, Shanghai, 201107

E-mail : sales@rigel-group.com

Website : www.rigel.com.cn

NINGBO RIGEL BATHROOM MARKETING CO., LTD (宁波锐佳卫浴销售有限责任公司) |

Sales & Marketing Office

Address : No. 11th, Meishan Avenue Business Centre, Room Nos. 3726, Beilun District, 315832, Zhejiang, China

Tel Number : (86) 574 5626 1876

Fax : (86) 574 5626 1588

E-mail : sales@rigel-group.com

Website : www.rigel.com.cn

RIGEL TECHNOLOGY (NINGBO) CO., LTD (锐佳科技宁波有限公司) | Manufacturing Plant

Address : No. 6, Chuangye Road 3, Ningbo Beilun Free Trade West Zone, 315800 Ningbo, Zhejiang China

Tel Number : (86) 574 5626 1688

Fax : (86) 574 5626 1588

E-mail : sales@rigel-group.com

Website : www.rigel.com.cn

RIGEL TECHNOLOGY CERAMICS (SICHUAN) CO., LTD 锐佳科技陶瓷工业（四川）有限公司 |

Manufacturing Plant

Address : No. 18, Shuanghechang, Anfu Town, Naxi District, 646300 Luzhou City 3 Sichuan, China

Tel Number : (86) 830 4270 028

Fax : (86) 830 4270 636

E-mail : sales@rigel-group.com

Website : www.rigel.com.cn

CUSTOMER SUPPORT

AFTER SALES SERVICE

Rigel's Customer Support Team can provide you with service visits, sale of spare parts, and general product help and advise.

SPARE PARTS

Spare parts for all Rigel products are available for up to 10 years after the product's date of final manufacture. You should only purchase spare parts directly from our Customer Support Department, or from Rigel's approved stockists or merchants to ensure authenticity and to maintain validity of your warranty.

NOTE: As a safety precaution, spare parts that require exposure to voltage from the power grid mains will only be send to qualified personnel.

SERVICE GUARANTEE

All servicing provided by Rigel will be performed by a trained technician or agent, with genuine spare parts, and will come with a 6-month warranty on the repair. Servicing outside of the product's warranty will be charged at a reasonable cost

SINGAPORE (HQ)

RIGEL TECHNOLOGY (S) PTE LTD | Headquarters & Showroom
 Address : RIGEL INNOVATION CENTRE | No. 20 Changi Business Park Central 2 Singapore 486031
 Tel Number : (65) 6812 6288
 Fax : (65) 6812 6388
 E-mail : sales@rigel-group.com
 Website : www.rigel.com.sg

MALAYSIA

RIGEL TECHNOLOGY (M) SDN BHD | Office & Showroom
 Address : Wisma Rigel, No. 16 & 18, Jalan 3/33B, MWE Commercial Park, 6 ½ Miles, Off Jalan Kepong, 52000 Kuala Lumpur, Malaysia
 Tel Number : (603) 6258 6016
 Fax : (603) 6258 5498
 E-mail : sales.my@rigel-group.com
 Website : www.rigel.com.my

INDONESIA

PT. RIGEL MARKETING INDONESIA | Office & Showroom
 Address : Jl. Sultan Iskandar Muda No. 99B, Arteri Pondok Indah, Gandaria Jakarta Selatan 12240, Indonesia
 Tel Number : (62) 21 2277 1188
 Fax : (62) 21 2277 1199
 E-mail : sales.id@rigel-group.com
 Website : www.rigel.id

PART LIST & ILLUSTRATIONS

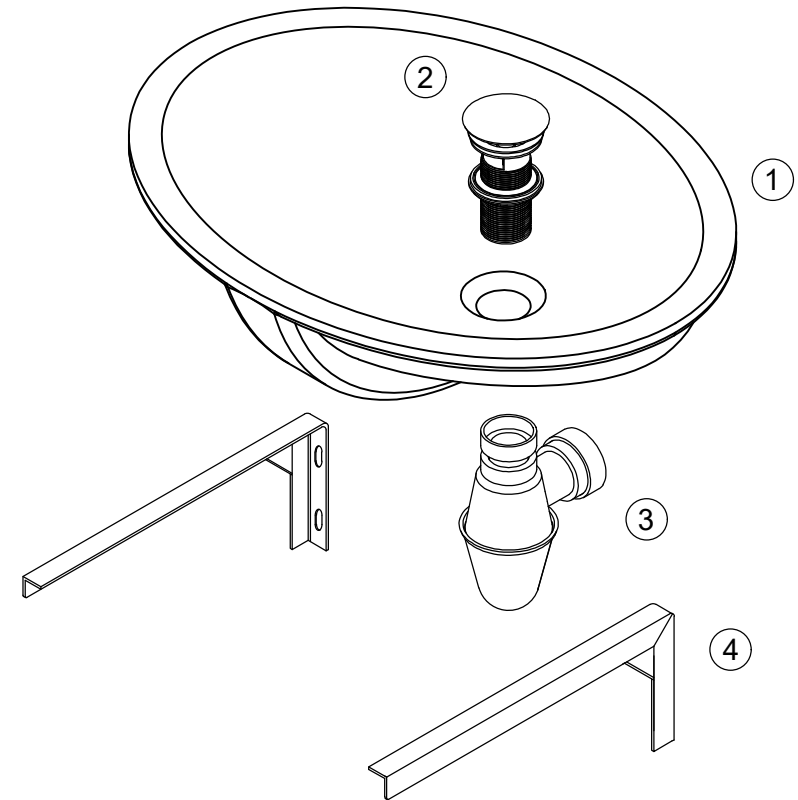

NO.	PART NO.	DESCRIPTION	QTY
①	R-LU1119	UNDERCOUNTER LAVATORY	1
②	FT-WSF114-A82	BASIN WASTE, FIXED, 1-1/4"	1
③	FT-BTR114X112-P	BOTTLE TRAP-UPVC, 1-1/4" X 1-1/2" (40MM)	1
④	FT-BRKLK	L SHAPE BRACKET FOR UNDERCOUNTER BASIN	1 SET

PRODUCT DIMENSIONS & INSTALLATION DIAGRAM

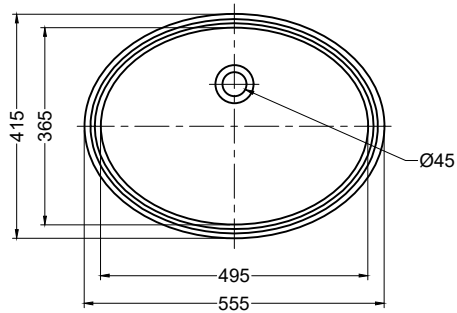

Top view

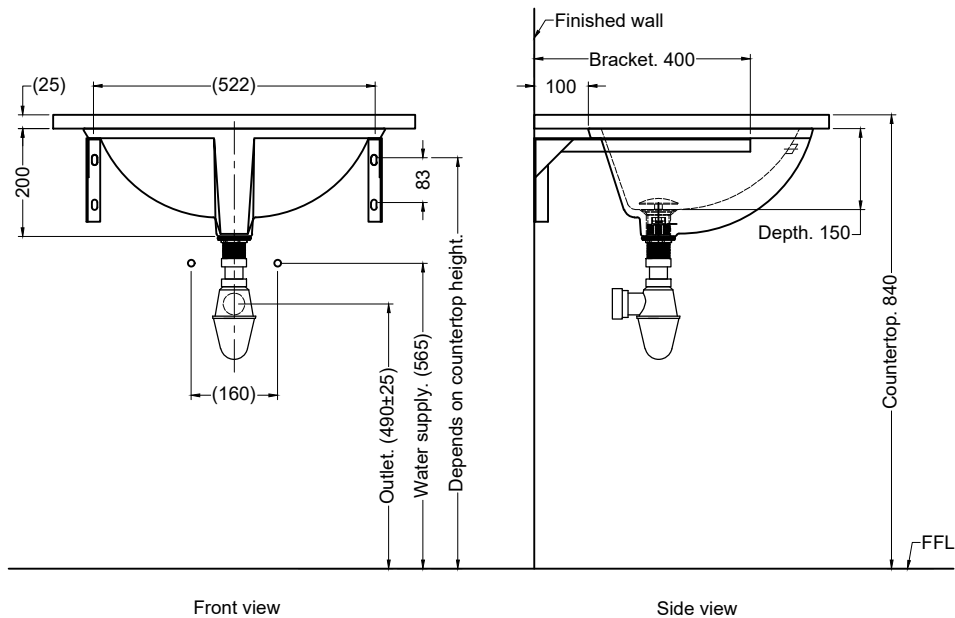

Front view

Side view

() Denotes recommended value.
All dimension are in mm.

WARRANTY

Please read the following warranty information thoroughly and retain this document for future use and reference.

Rigel Technology (S) Pte Ltd ("Rigel") warrants the products against any defect of materials or workmanship for a period of 1 year from the date of purchase.

Within the warranty period, all defective parts will be repaired and/or replaced free of charge.

To be eligible for free repair and/or replacement, any service work on the product must be undertaken by Rigel or our approved agents.

Service under this warranty will not affect the warranty expiry date, and any warranty on exchanged parts or products will end when the warranty expires.

This warranty is only applicable for products properly installed and operated in accordance to the operating procedures stated in the instruction manual.

This warranty does not extend to washroom accessories or other peripheral items.

Rigel's responsibility under this warranty does not apply to damage/defects caused by:

- Misuse, negligence, or accidents.
- Public abuse or vandalism.
- Repairs or alterations not authorized by or performed without consultation from Rigel.
- Repairs or alterations that do not comply with Rigel's installation instruction.
- Repairs or alterations that were not performed with genuine parts supplied by Rigel.

Rigel will not be held liable for any incidental or consequential damages, including loss of profits or savings, arising from the use or misuse of the products.

The terms in this warranty are only valid after:

- Full payment has been made.
- The official Warranty Card is completely and correctly filled out in ink and returned to Rigel within 14 days of purchase. Loss or misplacement of the Warranty Card, or unauthorized amendments to the Warranty Card, shall render the warranty null and void.

This warranty is in addition to your statutory and other legal rights.

PRODUCT CARE & CLEANING GUIDE

PRODUCT CARE & CLEANING Guide

The instructions contained herein are for the proper care and maintenance of the product, to ensure optimal function.

Please read the following care and cleaning information thoroughly and retain this document for future use and reference.

CARE AND CLEANING INSTRUCTIONS

Before commencing on the cleaning of your Rigel product with any cleaning agents, please read the directions on the cleaning agent to ensure that it is safe for use with the materials on your Rigel product.

Always test any new cleaning agents on a small, inconspicuous spot on your Rigel product before applying it on the entire surface.

	Recommended Cleaning Agents	Instructions
Routine cleaning	- Soap - Mild detergent - Warm water	Sponge along the polish lines and rinse with clean water. Wipe dry.
Fingerprint stains	- Soap - Warm water - Organic solvents (e.g. acetone, alcohol, methylated spirits)	Sponge the stains following the polish lines and rinse with clean water. Wipe dry.
Stubborn stains or discolouration	- Mild abrasive cleaning products - Specialty stainless steel cleaning products	Use a rag, sponge or soft brush to apply the cleaning agent, rubbing or brushing along the polish lines. Rinse well with clean water and wipe dry.

NOTE : Avoid the use of harsh chemicals and/or abrasive materials to clean your Rigel product as they may void your warranty.

INSTALLATION GUIDE

1.

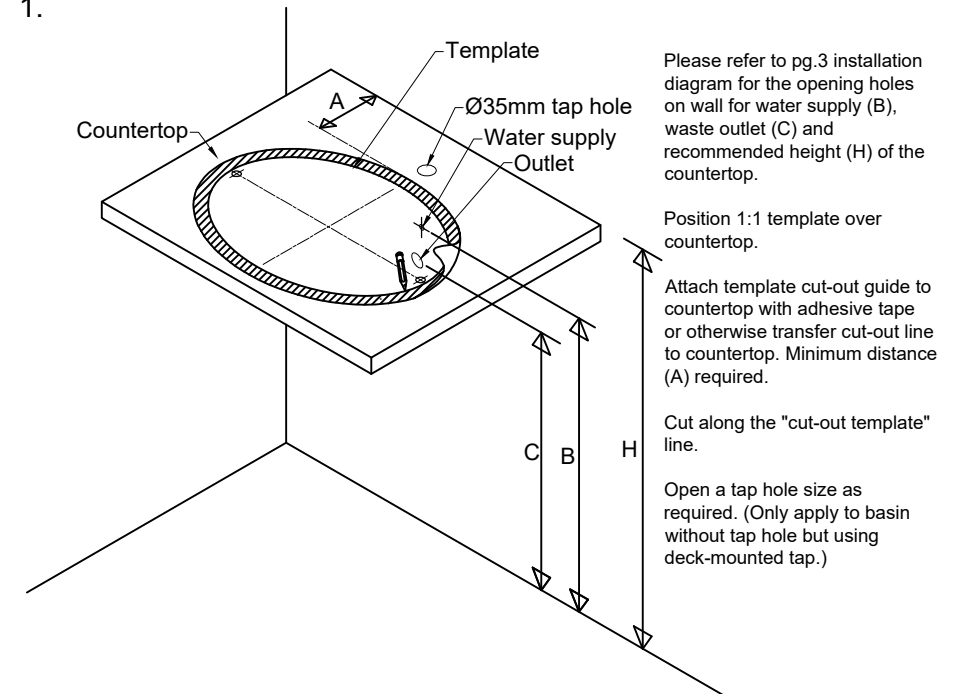

2.

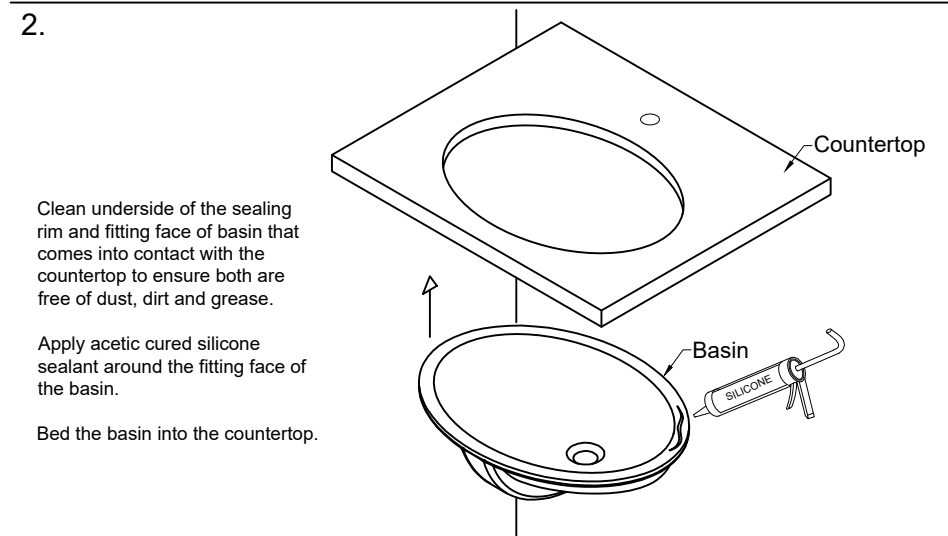

- Items shown are for illustrations purpose only, and therefore may not reflect actual model supplied.
- Please read the instructions carefully before doing any installations.

INSTALLATION GUIDE

3.

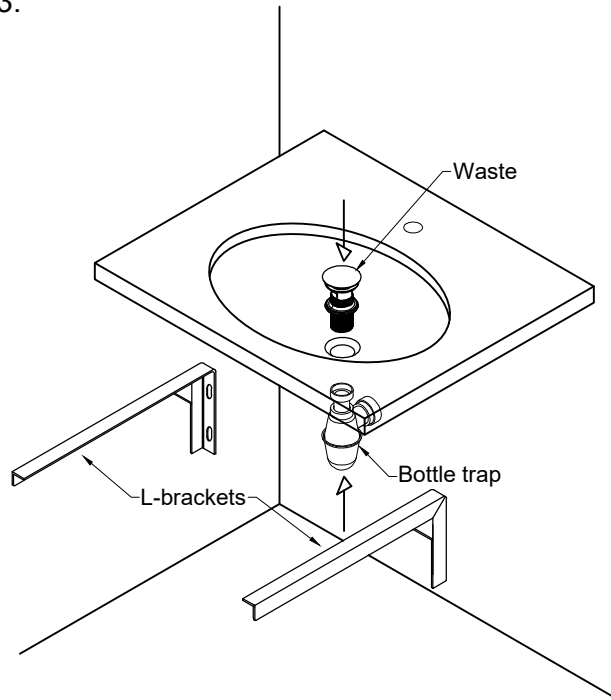

Use bracket clips underneath the counter / request a helper to hold on the basin while preparing to place the L-brackets.

Place the L-brackets below the basin, drill holes and tighten them with the screws.

L-brackets mounting location and height refer to the pg.3 installation diagram.

Connect waste assembly to the trap and all necessary fittings.

4.

Apply a layer of acetic cured silicone sealant around the sealing rim underneath the countertop.

Clean excess of silicone sealant around basin.

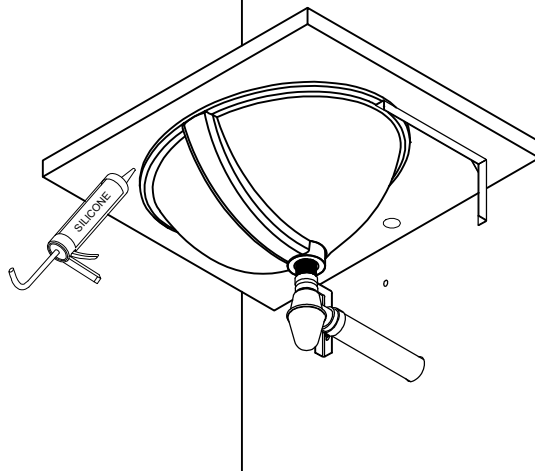

GENERAL SPECIFICATIONS

Dimensions	555(L) X 415(W) X 200(H)mm
Material	Vitreous China

TROUBLE SHOOTING GUIDE

OUT-OF-BOX FAILURE

If the product does not function as specified or reasonably expected upon first use after installation, please contact your contractor or trades person to check if the installation and commissioning are performed satisfactorily and in accordance with the instructions in the Installation Manual. You or your installer may contact Rigel for any advise and we will be glad to be of assistance. Should this still not resolve the issue, please contact our Customer Support Department and we will arrange for a visit by a Rigel service technician if necessary.

PERFORMANCE DECLINE

If the product is exhibiting a noticeable decline in performance after substantial use, please refer to the Product Care and Cleaning section of this Manual to check if simple home maintenance is required. Should product performance not improve after simple home maintenance is performed as per the instructions in the Product Care and Cleaning section, please contact our Customer Support Department to discuss the issue you are facing, and to request for service under warranty if applicable.

- Items shown are for illustrations purpose only, and therefore may not reflect actual model supplied.
- Please read the instructions carefully before doing any installations.

5.

6.